

Metal Injection Molding Transforms Pump Components

Sintex Metal Injection Molding (MIM) technology has successfully transformed a ventilation plug for pumps, reducing its weight from 54.4 grams to just 17 grams, resulting in a material savings of 37.4 grams of AISI 316L Stainless Steel per component. By leveraging advanced MIM technology, the plug's length was cut down from 27.5 mm to 8.6 mm, enhancing corrosion resistance while improving overall durability.

Metal Injection Molding Transforms Pump Components

37.4

Grams of Material Saving per Component

A ventilation plug for a pump was in the old version produced from rod bar materials in AISI 316L stainless steel with a cold forging process followed by a tread rolling process. The plug had a weight of 54,4 gram.

In collaboration with our customer's designers, The Sintex MIM-team redesigned the component for the next generation pumps, resulting in a weight reduction to 17 grams. This effort saved 37,4 grams of AISI 316L material for each component produced.

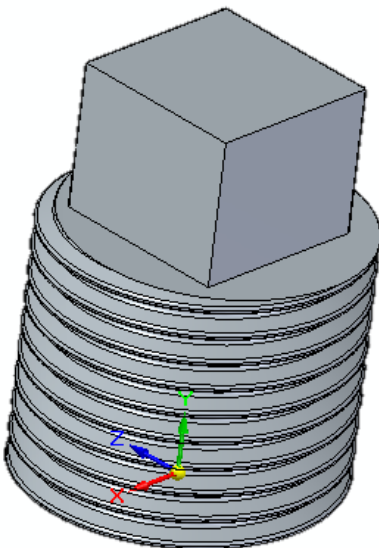

Figure 1: Former Component Design

The Power of Designing with MIM

- We knew that corrosion resistance of a rod bar was bad in the center core. Therefore, the old version needed to be long in order to ensure a long lifetime to compensate for the corrosion properties. We developed MIM AISI 316L with a very high and homogeneous corrosion strength enabling us to reduce the length of the plug from 27,5 mm to 8,6 mm.
- The cold forged version went through a handful of different operations like cutting, lubrication, cold forging, threading, deburring and washing. These processes had a high impact on the LCA (Life Cycles Assessment) where the washing process is a high runner in water and energy consumption. By changing to MIM, the part could be finalized in one shot and no washing was further needed.



Figure 2: MIM Feedstock

Conversion to MIM

- In the preparation of the injection tool we were able to introduce features that could not be made by machining. The surface was made in an aesthetic roughness with submerged customer logo inserted. Furthermore, the surface in the sealing recess was made smooth in order to secure a proper sealing with an O-ring. Finally, we also introduced tracking number as well as version indicator as the plug was introduced in two corrosion resistance qualities.
- The original plug was made with a special squared notch. Often such a notch was damaged when the plunger installed or repaired the pump installation. By changing into an Allen key a new level of robustness was introduced.



Figure 3: CM Pump with MIM Plug

Why did the customer benefit from MIM?

For instance, the conversion to MIM ensured the following:

- Total weight reduction of 37,4 grams
- A part that could be finalized in one shot with no further need for washing.
- Higher degree of robustness in the field
- Better corrosion resistance
- Greater Life Cycle Assessment
- European Production

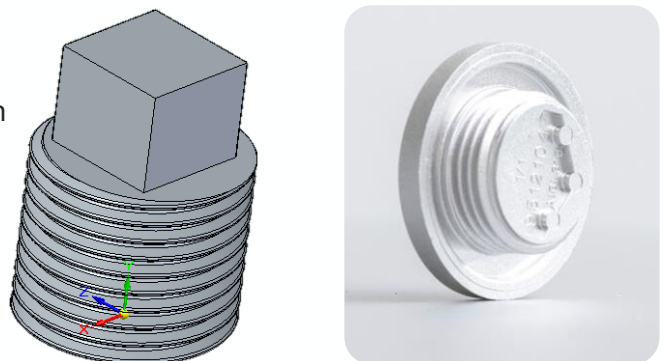

Figure 4: Comparison between former design (left) and current design (right)

Rethinking Components of Tomorrow

E-mail: info@sintex.com
Tel.: (+45) 9657 4300
www.sintex.com
